

RNR MACHINERY MOVERS

Features:

- Heavy duty capacities up to 5 tons - the most economical way to lift and move large bulky loads.
- Swivel casters allow movement in any direction.
- Hand operated hydraulic jack for easy lifting and controlled lowering of loads.
- All models supplied with hooks for recommended optional LB-1 or LB-2 load binders.

Model: **RNR-6P**
 Lift: 12"
 Casters: 6" X 2.5"
 Polyurethane
 Weight: 359 lbs/pair
 Capacity: 6,000 lbs/pair
 OD Fork Span Range: 6" to 19.5"

AFTER 2155XX SERIAL NUMBERS SEE PAGE 1
 BEFORE 2148XX SERIAL NUMBERS SEE PAGE 2

REPLACEMENT PARTS LIST

ITEM	P/N	DESCRIPTION	QTY
1	270426	JACK: 1-1/2 TON, RNR-2/6	2
2	108149	SCREW: HEX HD CAP (5/16-18X1)	4
3	100170	WASHER: LOCK 5/16 MED SPLIT	4
4	100069	WASHER: FLAT (PLTD) 5/16 SAE	4
5	108843	CASTER: SWIVEL 6X2-1/2 POLY	4
6	109637	BOLT: CARRIAGE 1/2-13X1-1/2"	16
7	108200	WASHER: FLAT (PLTD) 1/2" SAE	16
8	108228	WASHER: LOCK (PLTD) 1/2" MED	16
9	100366	NUT: HEX (PLTD) 1/2-13	16
10	106172	TUBING: FLEXO	2
11	106167	STRIP: RUBBER	2
12	051717	HANDLE: JACK (RNR-2/6/8/10)	1
OPTION: LOAD BINDER ACCESSORY			
	260096	LB-1 LOAD BINDER SET W/ DELTA RINGS	1
	260147	LB-2 LOAD BINDER SET W/ "E" TRACK HOOKS	1

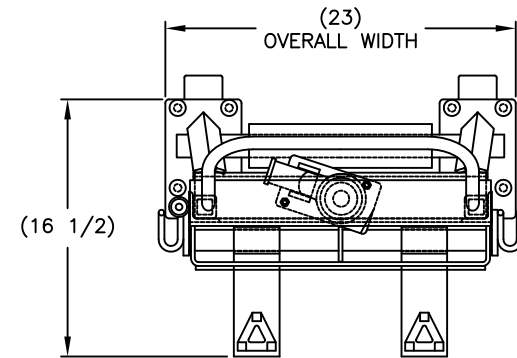
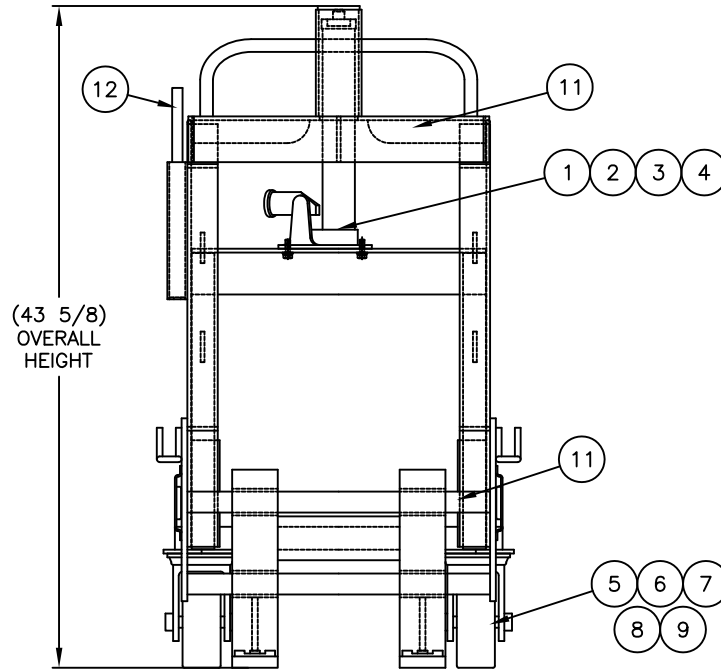
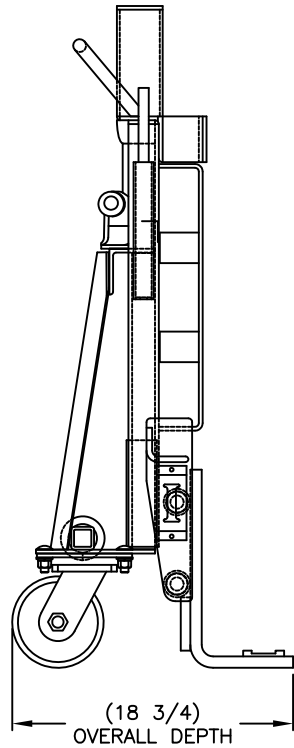

THIS DRAWING IN ALL PARTICULARS IS WESCO INDUSTRIAL PRODUCTS, LLC PROPERTY. ALL RIGHTS OF DESIGN, INVENTION OR USE OF ARE RESERVED.

PRINT ISSUED

FEB 20, 2018

WESCO MANUFACTURING
ENGINEERING DEPARTMENT

REV. ECH & DATE	REVISIONS		APP.	
	WESCO INDUSTRIAL PRODUCTS, LLC			
	PART NAME		NORTH WALES PENNA. 19454	
	RNR-6P		DRAWING: PS 7-25-00	
TOLERANCE UNLESS OTHERWISE SPECIFIED				
FRACTION		3 PLACE DECIMAL	2 PLACE DECIMAL	
± 1/64		± .005	± .01	
ANGULAR ± 1-1/2°		SHEET 1 OF 2		
BREAK ALL SHARP EDGES AND REMOVE ALL BURRS				
			SCALE:	C-260093

RNR MACHINERY MOVERS

Features:

- Heavy duty capacities up to 5 tons - the most economical way to lift and move large bulky loads.
- Swivel casters allow movement in any direction.
- Hand operated hydraulic jack for easy lifting and controlled lowering of loads.
- All models supplied with hooks for recommended optional LB-1 or LB-2 load binders.

AFTER 2155XX SERIAL NUMBERS SEE PAGE 1
 BEFORE 2148XX SERIAL NUMBERS SEE PAGE 2

REPLACEMENT PARTS LIST

1	151120	JACK: 1-1/2 TON, RNR-2/6	2
2	108843	CASTER: SWIVEL 6x2-1/2"	4
3	051717	HANDLE: JACK (R-N-R)	2

Model: **RNR-6P**
 Lift: 6"
 Casters: 6" X 2.5"
 Urethane
 Weight: 306 lbs/PR
 Capacity: 6,000 lb per pair

OD fork span range: 6" to 19.5"

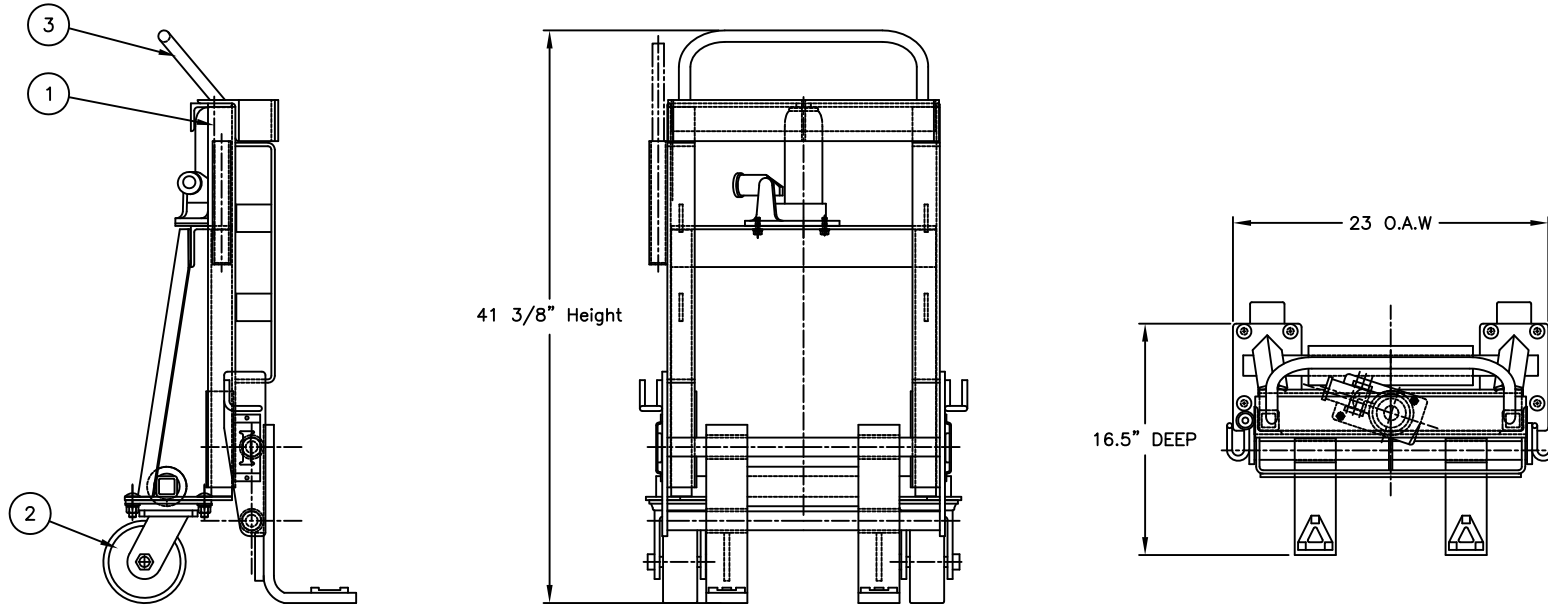

THIS DRAWING IN ALL PARTICULARS IS WESCO INDUSTRIAL PRODUCTS, LLC PROPERTY. ALL RIGHTS OF DESIGN, INVENTION OR USE OF ARE RESERVED.

PRINT ISSUED

DEC 29, 2004

WESCO MANUFACTURING
 ENGINEERING DEPARTMENT

REV. ECH & DATE	REVISIONS		APP.	
	WESCO INDUSTRIAL PRODUCTS, LLC			
	PART NAME		DRAWING	
	RNR-6P		PS 7-25-00	
TOLERANCE UNLESS OTHERWISE SPECIFIED				SCALE: 1" = 7"
FRACTION		3 PLACE DECIMAL	2 PLACE DECIMAL	APP. ENGR.
± 1/64		± .005	± .01	
ANGULAR ± 1-1/2°		SHEET 2 OF 2		C-260093
BREAK ALL SHARP EDGES AND REMOVE ALL BURRS				