

# RNR MACHINERY MOVERS

**Features:**

- Heavy duty capacities up to 5 tons - the most economical way to lift and move large bulky loads.
- Swivel casters allow movement in any direction.
- Hand operated hydraulic jack for easy lifting and controlled lowering of loads.
- All models supplied with hooks for recommended optional LB-1 or LB-2 load binders.

Model: **RNR-10**  
 Lift: 6"  
 Casters: 8" X 2.5"  
 Steel  
 Weight: 475 lbs/pair  
 Capacity: 8,000 lbs/pair  
 OD Fork  
 Span Range: 6" to 19.5"

## REPLACEMENT PARTS LIST

ITEM	P/N	DESCRIPTION	QTY
1	270427	KIT: REPLACEMENT JACK PRO-LIFT RNR8/10	2
2	-	NOT USED	-
3	-	NOT USED	-
4	-	NOT USED	-
5	108837	CASTER: SWIVEL 8x2-1/2" (STEEL)	4
6	109637	BOLT: CARRIAGE 1/2-13X1-1/2"	16
7	108200	WASHER: FLAT (PLTD) 1/2" SAE	16
8	108228	WASHER: LOCK (PLTD) 1/2" MED	16
9	100366	NUT: HEX (PLTD) 1/2-13	16
10	106172	TUBING: FLEXO	2
11	106167	STRIP: RUBBER	2
12	051717	HANDLE: JACK (RNR-2/6/8/10)	1
OPTION: LOAD BINDER ACCESSORY			
	260096	LB-1 LOAD BINDER SET W/ DELTA RINGS	1
	260147	LB-2 LOAD BINDER SET W/ "E" TRACK HOOKS	1

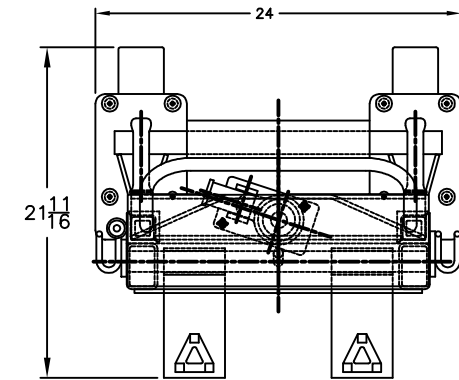
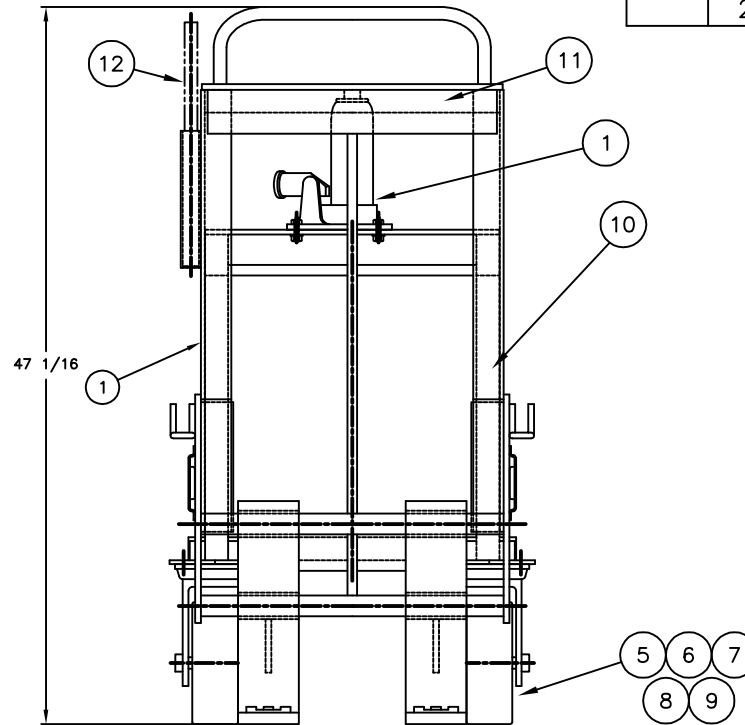
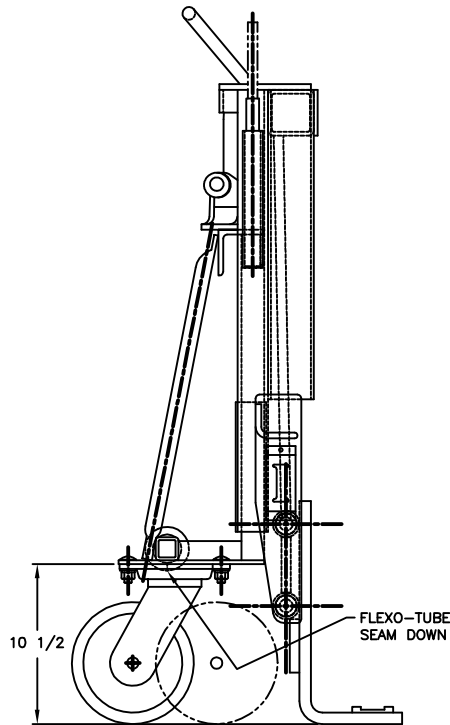

THIS DRAWING IN ALL PARTICULARS IS WESCO INDUSTRIAL PRODUCTS INC. PROPERTY. ALL RIGHTS OF DESIGN, INVENTION OR USE OF ARE RESERVED.

PRINT ISSUED

DEC 1, 2015

WESCO MANUFACTURING  
ENGINEERING DEPARTMENT

REV. ECH & DATE  
REVISIONS

<b>WESCO INDUSTRIAL PRODUCTS INC.</b>	
NORTH WALES	PENNA. 19454
PART NAME	<b>RNR-10</b>
DRAWN: PS 7-25-00	
CHECKED:	
APP. ENGR.	
TOLERANCE UNLESS OTHERWISE SPECIFIED	
FRACTION	3 PLACE DECIMAL      2 PLACE DECIMAL
± 1/64	± .005      ± .01
ANGULAR ± 1-1/2°	SHEET 1 OF 2
BREAK ALL SHARP EDGES AND REMOVE ALL BURRS	
SCALE:	<b>C- 260090</b>
REV	L