

RNR MACHINERY MOVERS

Features:

- Heavy duty capacities up to 5 tons - the most economical way to lift and move large bulky loads.
- Swivel casters allow movement in any direction.
- Hand operated hydraulic jack for easy lifting and controlled lowering of loads.
- All models supplied with hooks for recommended optional LB-1 or LB-2 load binders.

Model: RNR-8
Lift: 6"
Casters: 8" X 2.5"
 Steel
Weight: 475 lbs/pair
Capacity: 8,000 lbs/pair

OD Fork
Span Range: 6" to 19.5"

REPLACEMENT PARTS LIST

ITEM	P/N	DESCRIPTION	QTY
1	270427	KIT: REPLACEMENT JACK PRO-LIFT RNR8/10	2
2	-	NOT USED	-
3	-	NOT USED	-
4	-	NOT USED	-
5	108837	CASTER: SWIVEL 8x2-1/2" (STEEL)	4
6	109637	BOLT: CARRIAGE 1/2-13X1-1/2"	16
7	108200	WASHER: FLAT (PLTD) 1/2" SAE	16
8	108228	WASHER: LOCK (PLTD) 1/2" MED	16
9	100366	NUT: HEX (PLTD) 1/2-13	16
10	106172	TUBING: FLEXO	2
11	106167	STRIP: RUBBER	2
12	051717	HANDLE: JACK (RNR-2/6/8/10)	1
OPTION: LOAD BINDER ACCESSORY			
	260096	LB-1 LOAD BINDER SET W/ DELTA RINGS	1
	260147	LB-2 LOAD BINDER SET W/ "E" TRACK HOOKS	1

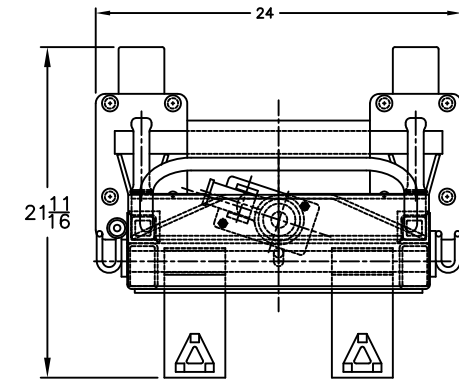
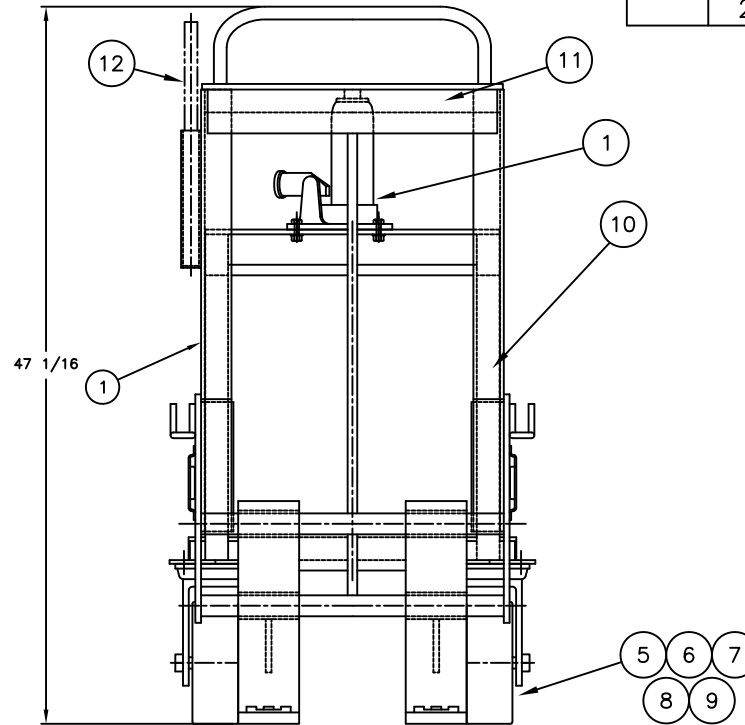
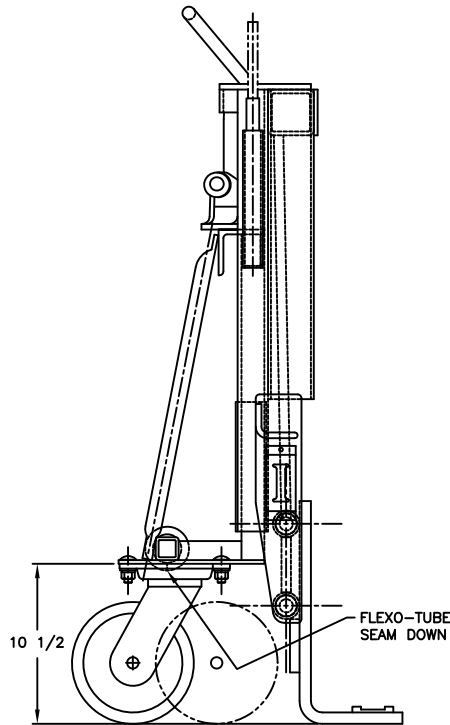

THIS DRAWING IN ALL PARTICULARS IS WESCO INDUSTRIAL PRODUCTS, LLC PROPERTY. ALL RIGHTS OF DESIGN, INVENTION OR USE OF ARE RESERVED.

PRINT ISSUED

APR 2, 2018

WESCO MANUFACTURING
ENGINEERING DEPARTMENT

REV. ECH & DATE REVISIONS APP.

WESCO INDUSTRIAL PRODUCTS, LLC		NORTH WALES PENNA. 19454	
PART NAME		DRAWN: PS 7-25-00	
RNR-8		CHECKED:	
TOLERANCE UNLESS OTHERWISE SPECIFIED		APP. ENGR.	
FRACTION	3 PLACE DECIMAL	2 PLACE DECIMAL	SCALE:
± 1/64	± .005	± .01	
ANGULAR ± 1-1/2°		SHEET 1 OF 2	C- 260089
BREAK ALL SHARP EDGES AND REMOVE ALL BURRS			REV