

DETAIL A
 SCALE 1 : 4

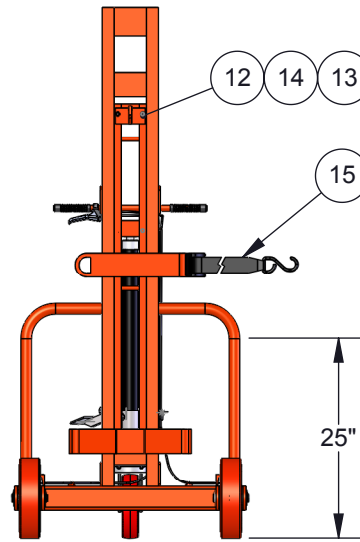
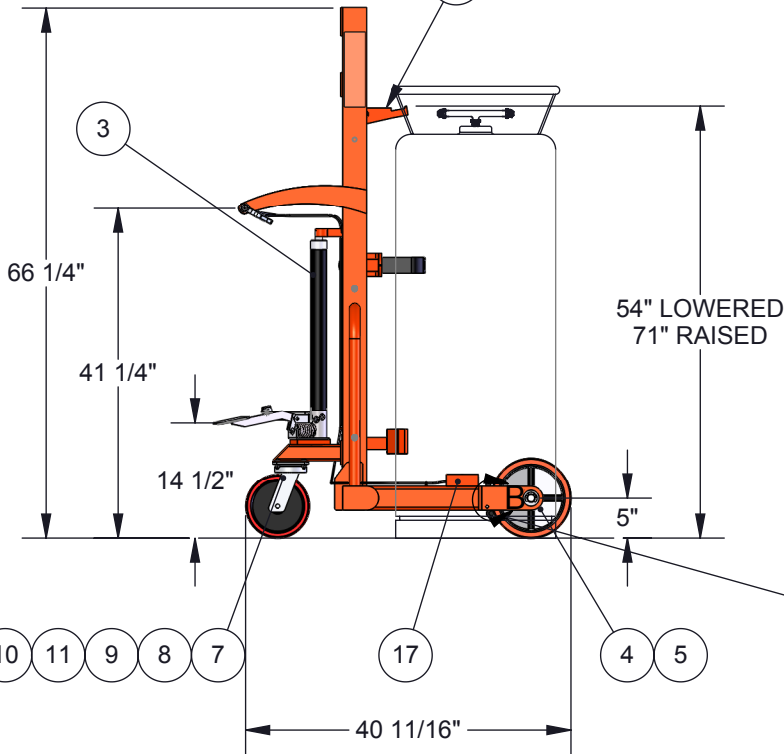

DETAIL B
 SCALE 1 : 6

Specifications:

Capacity: 1000 Lbs
 Lowered Height: 54"
 Raised Height: 71"
 Weight: 140 Lbs

NOTES:

- 10" Polyurethane-tread main load wheels
- 8" Polyurethane-tread total lock swivel caster
- Retractable ratchet strap makes securing load quick and easy W/ 2" wide X 72" long strap.
- 3 Wheel design makes maneuvering easy
- Hand brake for easy control

REPLACEMENT PARTS

ITEM	PART NO.	DESCRIPTION	QTY.
1	100457	RING: RETAINING 1/2", HVY. EXT. BL PHOS	6
2	050853	ROLLER: CARRIAGE (DM-1100)	6
3	054980	JACK: ASS'Y (40") HLCC	1
4	053730	WHEEL: 10" x 2-1/2" PPU ON POLY HUB	2
5	109363	RING: RETAINING "SE"TYPE 1" SHAFT	4
6	054958	WELDMENT:HOOK, HLCC	1
7	053732	CASTER: SWIVEL,8" CROWN POLY, TOTAL LOCK	1
8	108175	NUT: HEX (PLTD) 5/16-18	4
9	108149	SCR: HEX HD CAP (PLTD) 5/16-18x1"	4
10	100069	WASHER: FLAT (PLTD) 5/16 SAE	4
11	100170	WASHER: LOCK (PLTD) 5/16 MED SPLIT	4
12	105080	SCR: SCKT HD CAP 3/8-16x1-1/4", BLK	4
13	100642	HEX NUT 3/8-16	4
14	100217	LOCKWASHER 3/8 DIA.	4
15	109343	RATCHET: TIE DOWN, CARGO BUCKLE	1
16	054990	BRAKE ASS'Y: R.H. HLCC-B	1
17	054986	CHANNEL: BRAKE COVER, HLCC	2
18	054991	BRAKE ASS'Y: L.H. HLCC-B	1
19	055755	BRAKE LEVER ABT	1

PROPRIETARY

THIS DRAWING IN ALL PARTICULARS IS WESCO INDUSTRIAL PRODUCTS INC. PROPERTY. ALL RIGHTS OF DESIGN, INVENTION OR USE OF ARE RESERVED.



Manufacturers of Material Handling Equipment Since 1948
 NORTH WALES, PA 19454 PH: 215-699-7031

	NAME	DATE
DRAWN	DR	08/29/13
CHECKED		
ENG APPR.		

TITLE:
**HYDRAULIC LIQUID CYLINDER
 CART W/ BRAKES**

TOLERANCES
 UNLESS OTHERWISE SPECIFIED
 DIMENSIONS ARE IN INCHES
 FRACTIONAL ± 1/64
 ANGULAR: ±1.5°
 TWO PLACE DECIMAL ±0.01
 THREE PLACE DECIMAL ±0.005

PROJECT:
 HLCC

SIZE DWG. NO. REV
A 240251 A

SCALE: 1:24 WEIGHT: 140 lb. SHEET 1 OF 1