

210331

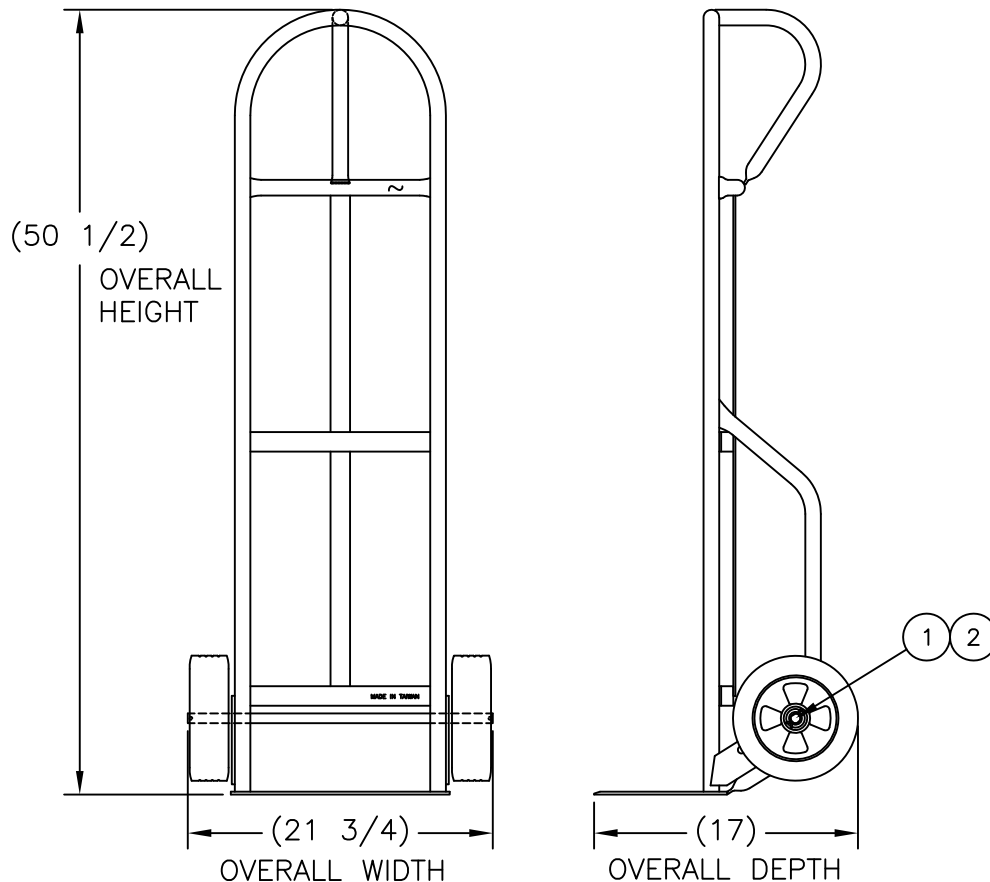

REPLACEMENT PARTS LIST

ITEM	PART NO.	DESCRIPTION	QTY.
1	108545	WHEEL "Z8" (8 ϕ X 2-1/2")	2
2	053900	AXLE "D" (19-1/2")	1

FOLDING NOSE EXT'N OPTION

ITEM	PART NO.	DESCRIPTION	QTY.
	210249	FNG-24K, FOLDING NOSE EXT'N	1
	050045	PIVOT ROD (FN-24)	1
	108232	RETAINING HOOK (FN-24)	1

GREENLINE STANDARD DUTY STEEL HANDTRUCKS
626D Series

- Single loop handle w/curved back design.
- Welded frame construction.
- 1" OD x 14ga wall tubular frame
- Economically priced.
- Green enamel finish.
- Zinc plated auto-loc axles assure smooth wheel rotation.
- 8" or 10" wheel on all frames
- 7" deep x 14" wide 7ga noseplate w/ radiused corners.

P/N 210331

Model 626D-Z8
 Weight 27 lbs
 Capacity 500 lbs
 Box NO

Wheel 8" x 2"
 Type Solid Rubber
 Hub Poly Offset

THIS DRAWING IN ALL PARTICULARS IS WESCO MFG. CO. PROPERTY. ALL RIGHTS OF DESIGN, INVENTION OR USE OF ARE RESERVED.

PRINT ISSUED

JUN 22 2007

WESCO MANUFACTURING
ENGINEERING DEPARTMENT

REV.	ECH & DATE	REVISIONS
A	01-24-13	UPDATED

WESCO MANUFACTURING CO.
 NORTH WALES PENNA. 19454

PART NAME

626D-Z8

DRAWN: LDU 8-19-99

CHECKED:

APP. ENGR.

TOLERANCE UNLESS OTHERWISE SPECIFIED

FRACTION	3 PLACE DECIMAL	2 PLACE DECIMAL
$\pm 1/64$	$\pm .005$	$\pm .01$

ANGULAR	SHEET	OF	1
$\pm 1-1/2'$	1	1	

SCALE:	1/8"=1"
B-	210331

SCALE: 1/8"=1"

REV	A
B-	210331

BREAK ALL SHARP EDGES AND REMOVE ALL BURRS