

492203

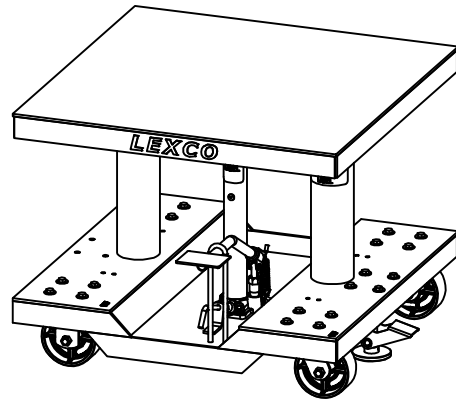

Foot and Electric Hydraulic Lift Table

- AC and DC power option available.
- 0.25" reinforced steel top and base.
- 2 rigid and 2 swivel 5" diameter steel wheels and 1 floor lock on 20" x 30" and 30" x 30" models.
- 4 swivel 5" diameter steel wheels and 2 floor locks on 30" x 40" models.
- Precision telescoping guide tubes.

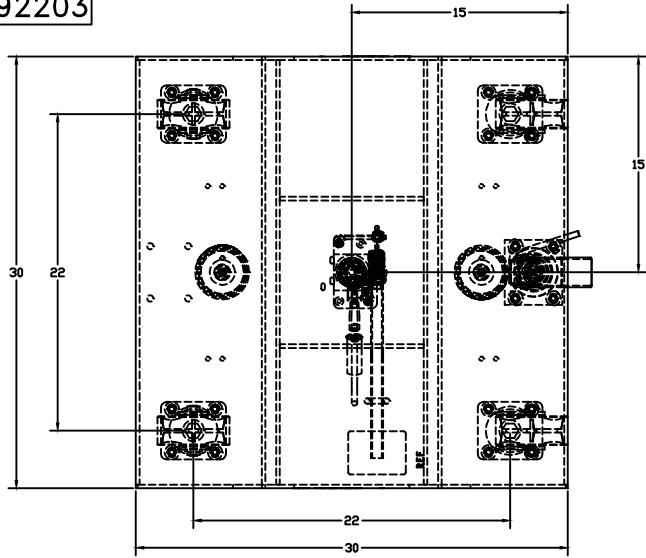
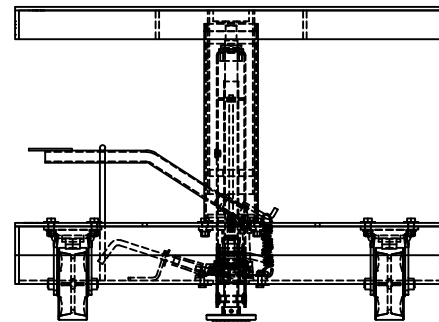
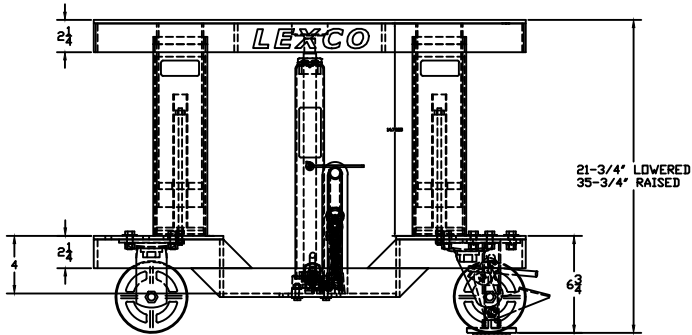

Specs

- Capacity: 2000 lbs
- Table size: 30" x 30"
- Lowered height: 20"
- Raised height: 32"
- Caster: 5"
- Lift: 12"
- Weight(foot opp.): 268 lbs
- Weight(electric opp.): 348 lbs

THIS DRAWING IN ALL PARTICULARS IS WESCO INDUSTRIAL PRODUCTS INC. PROPERTY. ALL RIGHTS OF DESIGN, INVENTION OR USE OF ARE RESERVED.

PRINT ISSUED

NOV. 21, 2008

WESCO MANUFACTURING
ENGINEERING DEPARTMENT

REV.	DATE	BY	APP.
A	6614 11/21/08	JL	APP.
		PRODUCTION RELEASE	

WESCO INDUSTRIAL PRODUCTS INC.		PENNA. 19446	
LANSDALE		DRAWN: J.L. 11-21-08	
PART NAME		CHECKED:	
HT-334-2F-A			
HT SERIES, LIFT TABLE		APP. ENGR.	
TOLERANCE UNLESS OTHERWISE SPECIFIED			
FRACTION	3 PLACE DECIMAL	2 PLACE DECIMAL	SCALE: 1" = 1"
± 1/8"	± .005	± .01	
ANGULAR ± 1-1/2'	SHEET 1 OF 1	492203	
BREAK ALL SHARP EDGES AND REMOVE ALL BURRS			REV. A