

**POWERED STACKERS**

**Features:**

- Adjustable base legs available on fork models.
- Fixed platforms 24x24, 24x27, 30x32
- Reinforced frame and base.
- Double chain, lift support.
- Heavy-duty pump.
- Ergonomic "D" handles.
- 110V AC models available.

**ADJUSTABLE FORK MODELS**

Model: PSFL-56-25-20S-1.5K  
 Lift Height: 56"  
 O.A.H: 72"  
 Weight: 485  
 Capacity: 1,500 lbs  
 Load Center: 15"  
 Fork W/L: 3"/25"  
 Base Leg ID/OD: 20"/26"

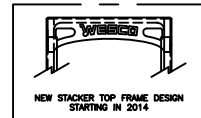
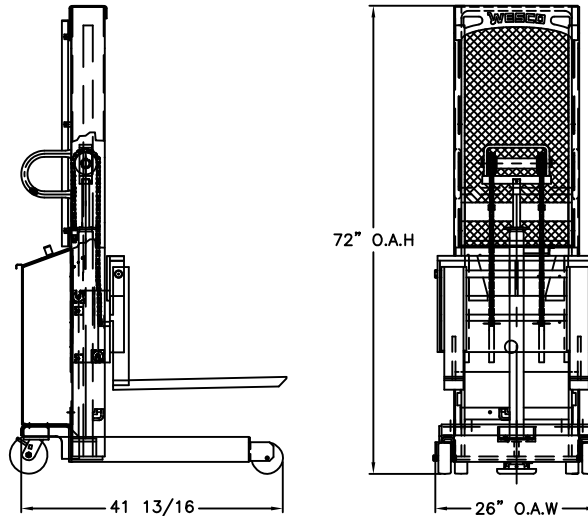
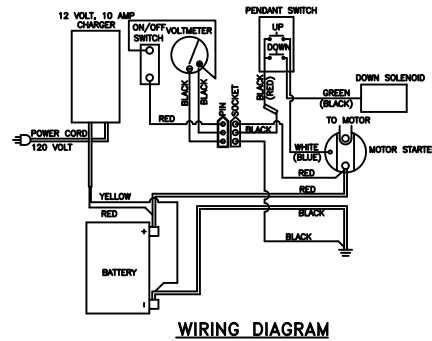

**1,500 LBS POWER STACKER PARTS LIST  
56"/60" LIFT**

1	051179	HYDRAULIC CYLINDER	1
2	109101	POWER UNIT	1
3	109102	BATTERY	1
4	109104	VOLTMETER	1
5	052779	BATTERY CABLE (NEG.)	1
6	052780	BATTERY CABLE (POS.)	1
7	109150	BATTERY CHARGER	1
8	125824	HYDRAULIC HOSE	1
9	052726	REMOTE CONTROL ASS'Y	1
10	109325	SWITCH	1
11	050781	LIFT CHAIN ASS'Y	2
12	050776	ROLLER CARRIER ASS'Y	2
13	052010	FLOOR LOCK	1
14	053769	WHEEL	2
15	150024	CASTER	2
16	109117	SOLENOID	1

**HYDRAULIC CYLINDER PARTS LIST**

17	051074	CYLINDER	1
18	051045	PISTON	1
19	050006	CYLINDER CAP	1
20	220171	SEAL KIT	1

THIS DRAWING IN ALL PARTICULARS IS WESCO INDUSTRIAL PRODUCTS INC. PROPERTY. ALL RIGHTS OF DESIGN, INVENTION OR USE OF ARE RESERVED.

PRINT ISSUED  
 OTC. 16, 2006  
 WESCO MANUFACTURING  
 ENGINEERING DEPARTMENT

APP	<b>WESCO INDUSTRIAL PRODUCTS INC.</b> NORTH WALES PENNA. 19454		
REV.	PART NAME	PSFL-56-25-20S-1.5K	
	DRAWN: KL 08-07-01		
ENGR.	CHECKED: PS 08-16-01		
	APP. ENGR.		
	SCALE: 1" = 20"		
REV.	TOLERANCE UNLESS OTHERWISE SPECIFIED		
	FRACTION	3 PLACE DECIMAL	2 PLACE DECIMAL
	± 1/64	± .005	± .01
ANGULAR ± 1-1/2'		SHEET 1 OF 2	B-261083
BREAK ALL SHARP EDGES AND REMOVE ALL BURRS			

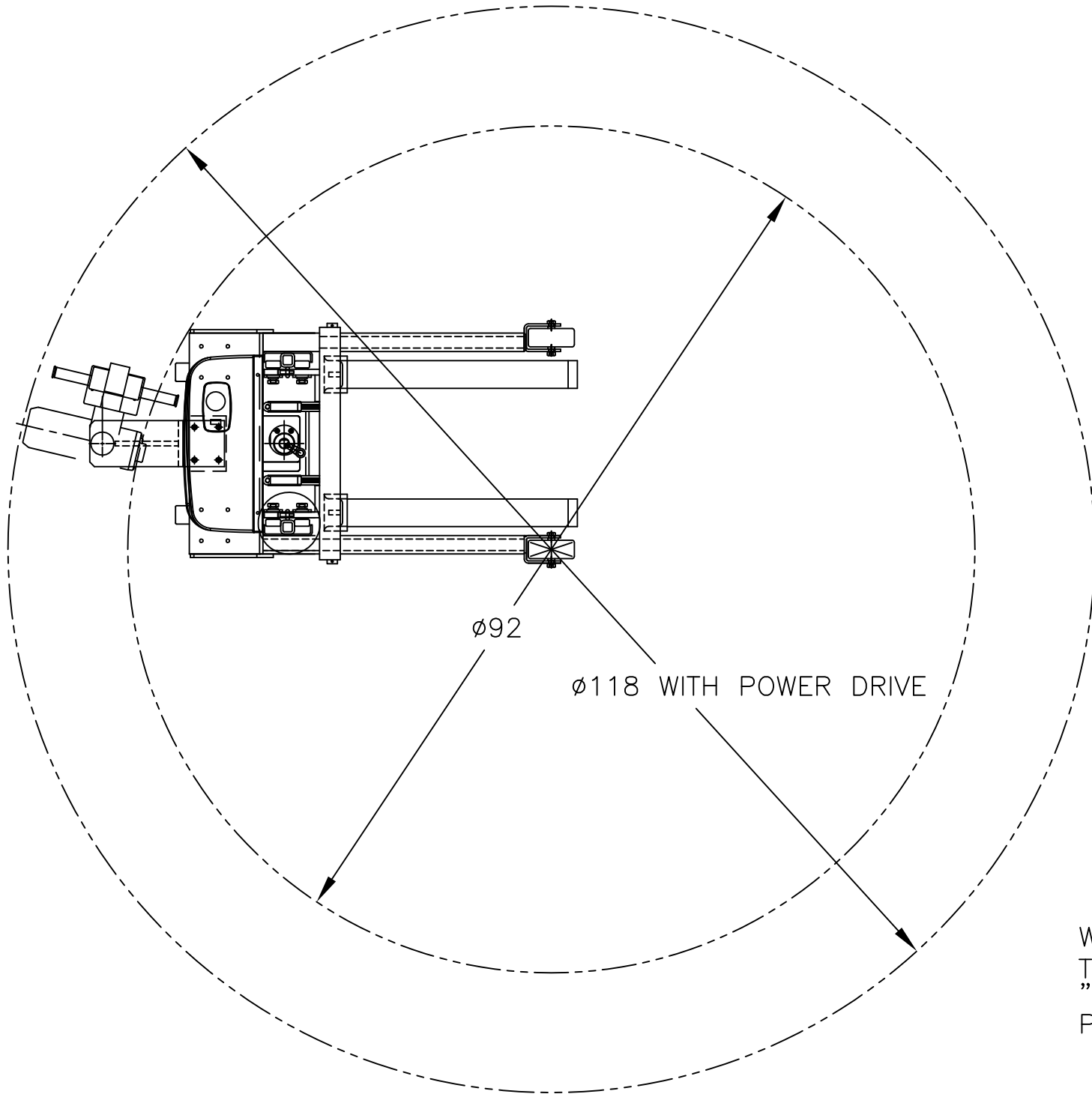

WESCO INDUSTRIAL PROD.  
TURNING CIRCLE  
"20S" STACKERS  
PART # 261083/261086  
& 261092/261095

P. SPENCER 10-09-09