

POWERED STACKERS

Features:

- Adjustable base legs available on fork models.
- Reinforced frame and base.
- Double chain, lift support.
- Heavy-duty pump.
- Ergonomic "D" handles.
- 110V AC models available.

PLATFORM MODELS

Model: PSPL-60-1824-15S-1.5K
 Lift Height: 60"
 O.A.H: 72"
 Weight: 450
 Capacity: 1,500 lbs
 Load Center: 15"
 Platform LxW: 18" x 24"
 Base Leg ID/OD: 15"/21"

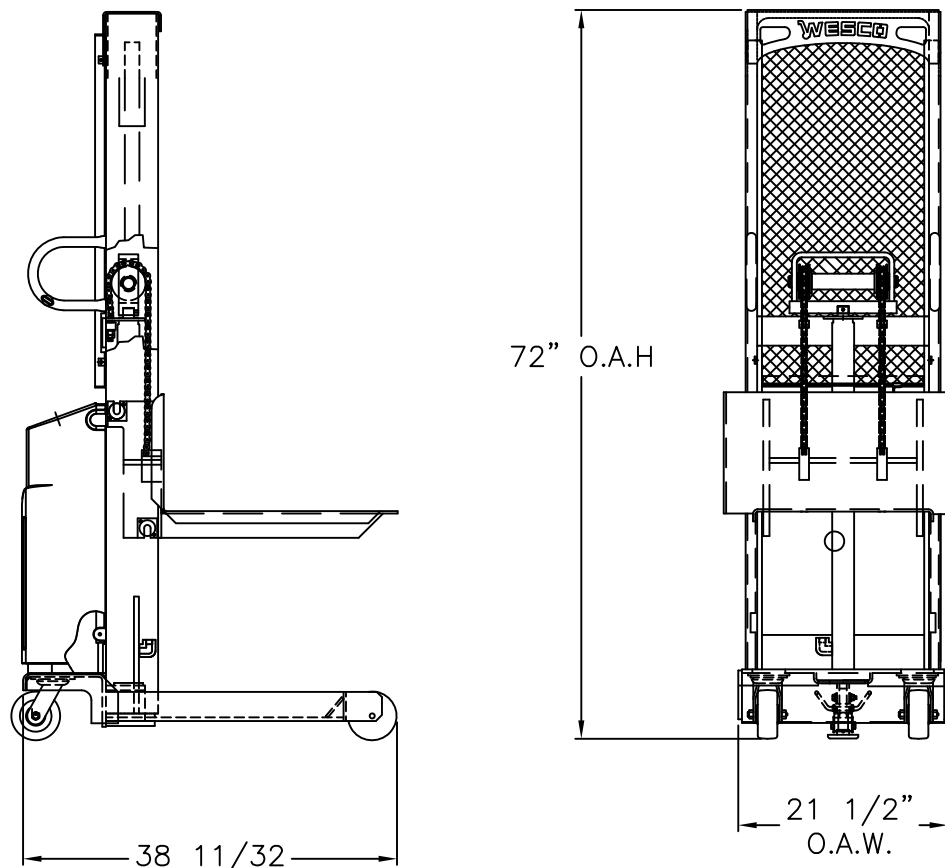
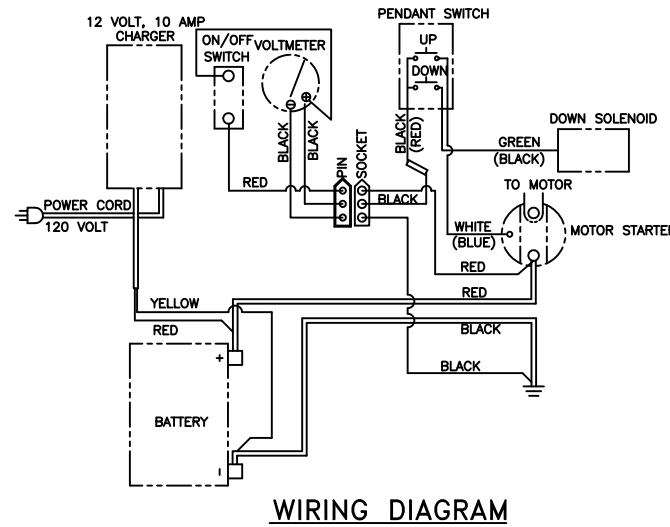

**1,500 LBS POWER STACKER PARTS LIST
56"/60" LIFT**

ITEM	P/N	DESCRIPTION	QTY
1	051179	HYDRAULIC CYLINDER	1
2	109101	POWER UNIT	1
3	109102	BATTERY	1
4	109104	VOLTMETER	1
5	052779	BATTERY CABLE (NEG.)	1
6	052780	BATTERY CABLE (POS.)	1
7	109150	BATTERY CHARGER	1
8	125824	HYDRAULIC HOSE	1
9	052726	REMOTE CONTROL ASS'Y	1
10	109325	SWITCH	1
11	050781	LIFT CHAIN ASS'Y	2
12	050776	ROLLER CARRIER ASS'Y	2
13	052010	FLOOR LOCK	1
14	053769	WHEEL	2
15	150024	CASTER	2
16	109117	SOLENOID	1

HYDRAULIC CYLINDER PARTS LIST

17	051074	CYLINDER	1
18	051045	PISTON	1
19	050006	CYLINDER CAP	1
20	220171	SEAL KIT	1

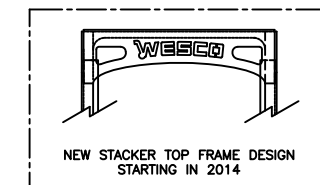

THIS DRAWING IN ALL PARTICULARS IS WESCO INDUSTRIAL PRODUCTS, LLC PROPERTY. ALL RIGHTS OF DESIGN, INVENTION OR USE OF ARE RESERVED.

PRINT ISSUED
 OCT. 02, 2018
 WESCO MANUFACTURING
 ENGINEERING DEPARTMENT

APP	WESCO INDUSTRIAL PRODUCTS, LLC	
	NORTH WALES PENNA. 19454	
EON & DATE	PART NAME	DRAWN: KL 08-07-01
	PSPL-60-1824-15S-1.5K	CHECKED: PS 08-16-01
	APP. ENGR.	
REVISIONS	TOLERANCE UNLESS OTHERWISE SPECIFIED	
	FRACTION	3 PLACE DECIMAL 2 PLACE DECIMAL
	± 1/64	± .005 ± .01
	ANGULAR ± 1-1/2°	SHEET 1 OF 2
REV.	BREAK ALL SHARP EDGES AND REMOVE ALL BURRS	

B- 261181