

260050

REPLACEMENT PARTS LIST  
56"/60" Stacker

1	260143	CHAIN ROLLER ASS'Y	1
2	050770	LIFT CHAIN ASS'Y (56/60")	1
3	108519	STABILIZER ROLLER	4
	051617	STABILIZER ROLLER KIT	
4	108517	PLATFORM ROLLER	4
5	053769	WHEEL: 5x2, PHENOLIC ASS'Y	2
6	054265	CASTER: SWIVEL 4x2 PHENOLIC	2
7	150001	FLOOR LOCK: NEW STYLE	1
8	051151	JACK ASS'Y (56/60")	1
	052723	SEAL KIT	1
	050750	PUMPING PEDAL ASS'Y (PL/SPL)	1
	050752	RELIEF PEDAL ASS'Y (PL/STCKR)	1
	050754	PUMPING RELEASE VALVE KIT	1
	050468	MAGNET SPACER ASS'Y	1

"S" STANDARD & "E" CONOMY LINE PLATFORM HYDRAULIC STACKERS

- Floor locks, safety screen and foot guard are standard on all models.
- Forks touch the floor on all fork models.
- Front phenolic wheels are 5" diameter.
- Rear Phenolic swivel casters are 4" diameter.
- Hydraulic jack manufactured by WESCO in U.S.A
- Frame and lift heights vary among models.
- "S" tandard line features one piece platform guide rail.
- "E" conomy line offers an economical price value.

LARGE ECONOMY PLATFORM MODEL

260050                      ESPL-60-3032

Platform:                      30x32 w/5.25" lowered height  
 Lift Height:                      60"  
 Load Center:                      18"  
 Base leg span:                      25.5" Inside  
     32" Outside  
 Weight:                              265 lbs  
 Capacity:                              1,000 lbs  
 Boxed:                                  No

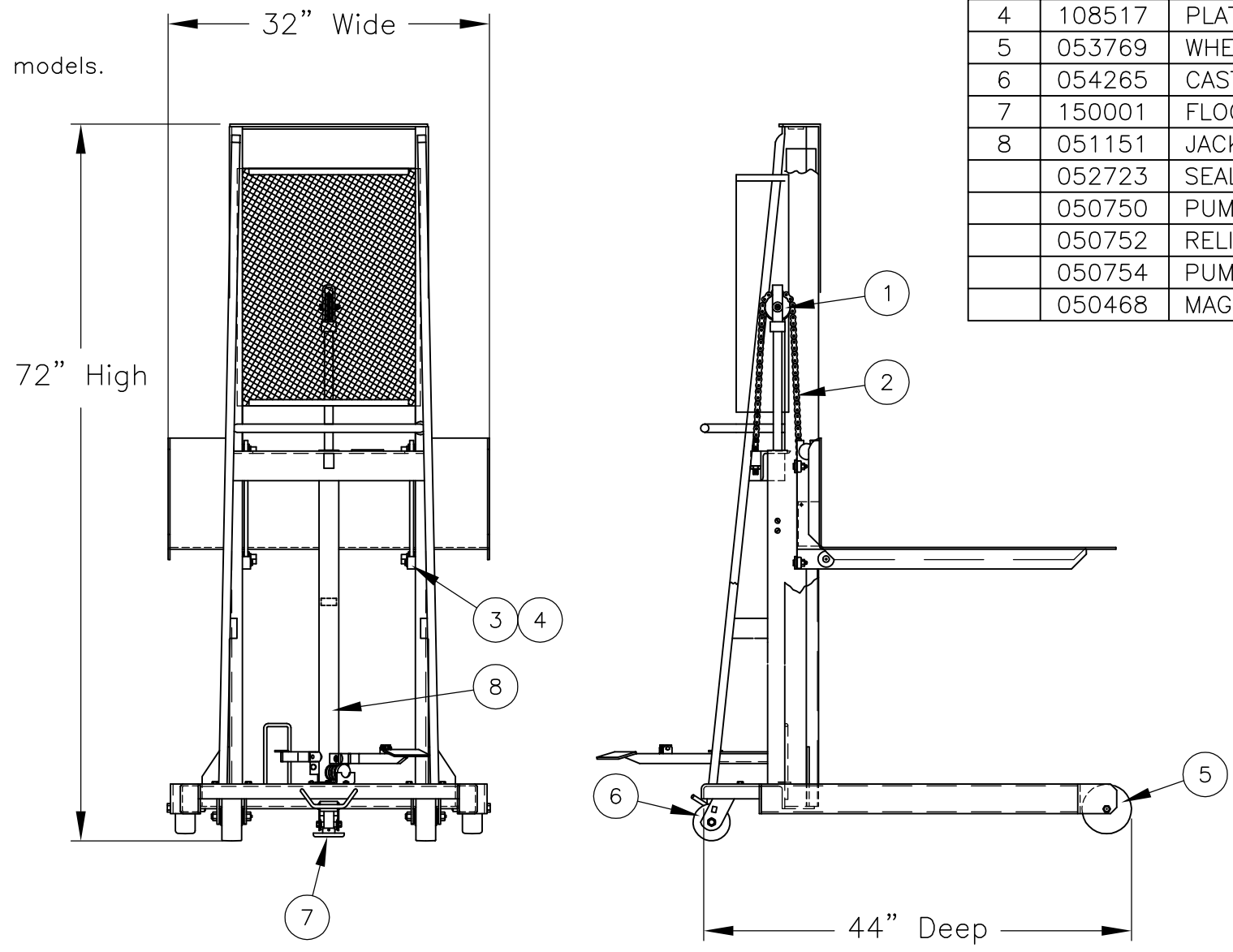

THIS DRAWING IN ALL PARTICULARS IS WESCO INDUSTRIAL PRODUCTS INC. PROPERTY. ALL RIGHTS OF DESIGN, INVENTION OR USE OF ARE RESERVED.

PRINT ISSUED  
 Oct. 12, 2006  
 WESCO MANUFACTURING  
 ENGINEERING DEPARTMENT

APP	WESCO INDUSTRIAL PRODUCTS INC.			
	LANSDALE	PENNA. 19446		
ECN & DATE	PART NAME	DRAWN: WEW 10-16-98		
	ESPL-60-3032	CHECKED:		
	TOLERANCE UNLESS OTHERWISE SPECIFIED	APP. ENGR.		
REV.	FRACTION	3 PLACE DECIMAL	2 PLACE DECIMAL	SCALE: 1" = 16"
	± 1/64	± .005	± .01	B- 260050      REV
	ANGULAR ± 1-1/2'	SHEET 1	OF 1	
	BREAK ALL SHARP EDGES AND REMOVE ALL BURRS			