

REPLACEMENT PARTS LIST

ITEM	PART NO.	DESCRIPTION	QTY.
1	150589	"Z" WHEEL (ø10 X 2 3/4)	2
2	050052	"D" AXLE (19 7/8")	1
3	051730	HANDLE	1
4	108492	SPRING FOR LOCK PINS	1
5	108447	SWI. CASTER, POLYOLEFIN (Plate Type)	2
	151244	3 1/2 COLSON CASTER (S23)	2

2-IN-1 DELUXE INDUSTRIAL STEEL HAND TRUCKS

P/N 210138
Model: 156-S23-Z
Weight: 60.5 lbs
Capacity: 700 lbs 2-Wheel
 1000 lbs 4-Wheel
Hub: Steel Offset
Dimensions: 10" x 2.75"
Wheel Type: Semi-Pneumatic
Boxed: NO

Height: 53"
Bed Size: 14" x 44.5"
Total Width: 22.5"

- Converts easily between 2 and 4 wheel truck.
- Handle locks in horizontal and vertical positions.
- Two lengthwise straps and two cross braces prevent package fall-through.
- 3.5" or 5" Colson hi-Tech Performa Casters
- 3/4" Schedule 40 structural pipe bed frame.

COLSON HI-TECH PERFORMA CASTERS:

- Standard equipment on all models at no additional cost.
- Less energy required to start moving load and keep it moving.
- Performa wheels reject almost every type of floor debris, including metal shavings, chips, sand and gravel.
- Smooth, quiet ride of a soft-tread wheel.
- As durable as a hard-tread wheel.

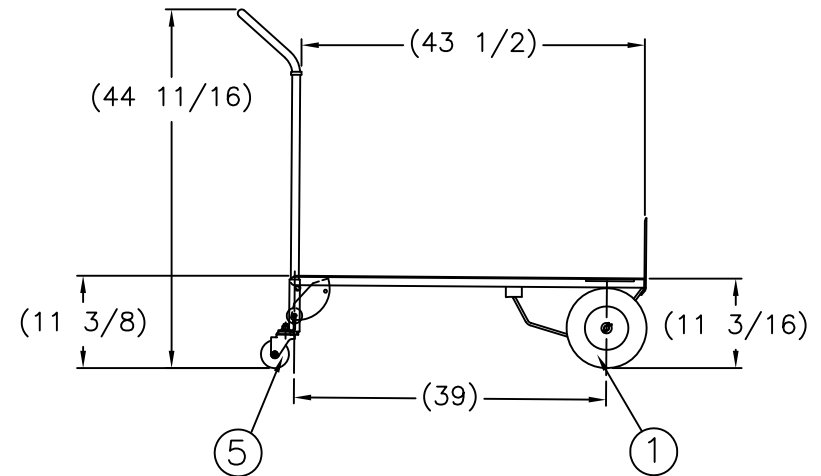
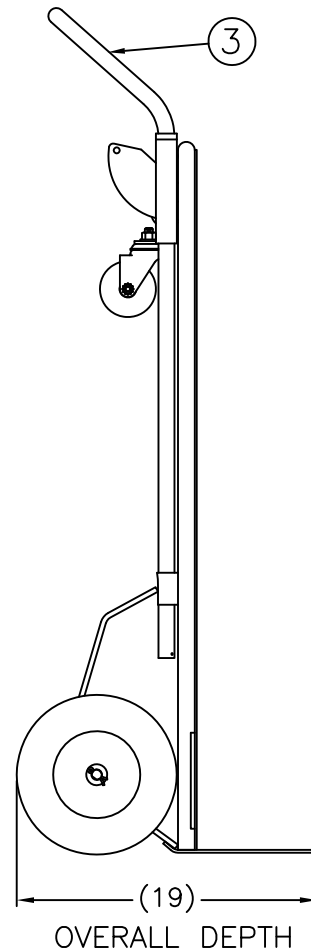
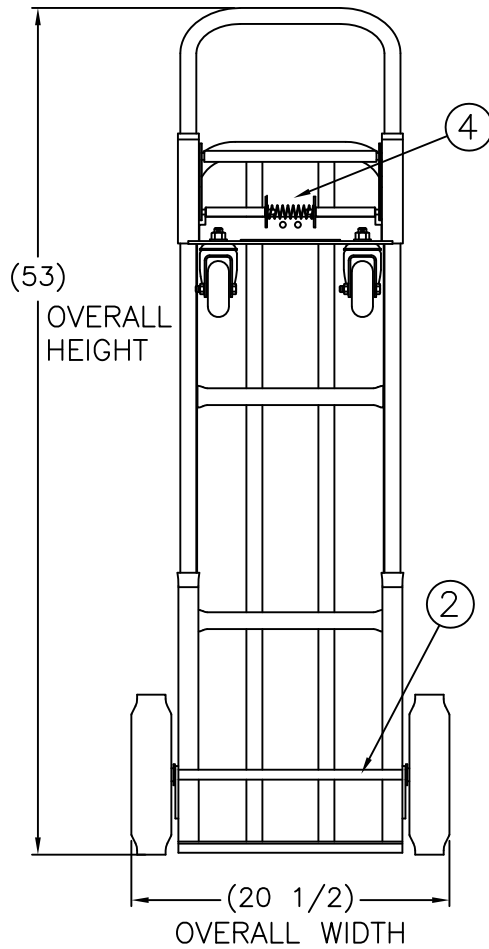

THIS DRAWING IN ALL PARTICULARS IS WESCO MFG. CO. PROPERTY. ALL RIGHTS OF DESIGN, INVENTION OR USE OF ARE RESERVED.

PRINT ISSUED

JAN 10, 2007

WESCO MANUFACTURING
ENGINEERING DEPARTMENT

REV.	DATE	BY	APP.
C	01-21-13	W	S
		UPDATED	

WESCO MANUFACTURING CO. NORTH WALES PENNA. 19454	
PART NAME 156-S23-Z	DRAWN: SKH 10-9-95 CHECKED: EGK 10-13-95 APP. ENGR.
TOLERANCE UNLESS OTHERWISE SPECIFIED	
FRACTION ± 1/64	3 PLACE DECIMAL ± .005
2 PLACE DECIMAL ± .01	SCALE: 6" = 1"
ANGULAR ± 1-1/2°	SHEET 1 OF 1
BREAK ALL SHARP EDGES AND REMOVE ALL BURRS	
C-210138	