

## REPLACEMENT PARTS LIST

ITEM	PART NO.	DESCRIPTION	QTY.
1	108545	WHEEL: "R" 8 X 1 5/8	2
2	210099	24 FLD. NOSE W/HRDWARE	1
3	050045	PIVOT ROD (FN-24)	1
4	108232	RETAINING HOOK (FN-24)	1
5	108226	1 PLASTIC GRIP (BLACK)	1
6	053528	AXLE: "D" 19	1

100 SERIES INDUSTRIAL  
HAND TRUCKS

- A 5 year guarantee against weld failure. A Wesco quality exclusive.
- Industrial strength heavy duty schedule 40 pipe frame construction.
- Ribbed cross braces for extra strength.
- All joints double welded.
- 8" deep x 14" wide nose is 7 gauge thick plate with machined beveled edge and radiused corners for safety.
- Zinc plated Auto-Loc axles assure smooth wheel rotation.
- All frame handle 8" or 10" wheels.
- Orange enamel finish.
- Vinyl handle grips are standard on appropriate frames.

## SERIES 126

- Single pin handle curved back design allows one hand control.
- Ideal for boxes, kegs, and packages.
- Three horizontal cross straps and full height vertical center strap offer support for small packages.

P/N                    210010  
 Model:                126-Z8  
 Capacity:            600 lbs  
 Weight:               38 lbs  
 Boxed:                No  
 Hub:                   Poly Offset  
 Dimensions:        8" x 2.5"  
 Wheel Type:        Solid Rubber

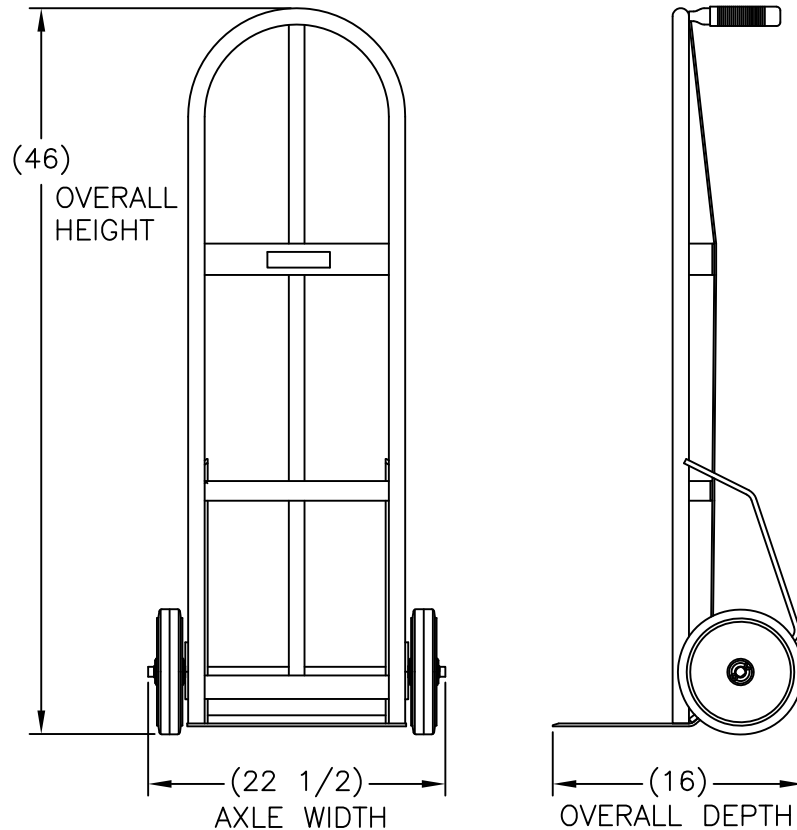

PRINT ISSUED

DEC 29, 2006

WESCO MANUFACTURING  
ENGINEERING DEPARTMENT

R	W	S	APP
01-16-13			
UPDATED			
A			

WESCO MANUFACTURING CO.			
NORTH WALES		PENNA. 19454	
PART NAME		DRAWN: LDU 8-3-00	
126-R		CHECKED:	
TOLERANCE UNLESS OTHERWISE SPECIFIED		APP. ENGR.	
FRACTION	3 PLACE DECIMAL	2 PLACE DECIMAL	SCALE: 8" = 1"
± 1/64	± .005	± .01	
ANGULAR ± 1-1/2'	SHEET 1	OF 1	B- 210009
BREAK ALL SHARP EDGES AND REMOVE ALL BURRS			REV A